

# VFORCE 3 INSTRUCTIONS



## MOTORCYCLE AND ATV INSTRUCTIONS:

### Installation Instructions:

**Caution:** Refer to your owner's service manual for detailed instructions and illustrations for removal of the carburetor, intake manifold and reed block.

1. Remove your stock reed cage assembly.
2. The following procedure is not necessary for most applications. If however, your rubber intake manifold has tabs that extend into the reed cage, they must be removed.  
Follow the steps below to remove rubber tabs:
  - a. Bolt stock cage to the manifold by using nuts, washers (supplied) and two intake bolts. Assemble by putting the two intake bolts through the top two holes in the manifold. Next, place the washer between the cage and manifold. Finally, tighten the nuts on the intake bolts. (Refer to diagram 2A at bottom of page)
  - b. Insert hack saw in gap between manifold and cage. Carefully cut tabs off manifold. (Refer to diagram 2B at bottom of page)
  - c. Disassemble and clean manifold.
3. Assemble using your new VForce3 reed valve(s) and modified stock manifold with supplied gaskets.
4. After installation is complete, take time to check and make sure everything is tight. Inspect all fuel and vent lines to be sure they are routed properly and free of damage and kinks.

### Jetting:

Jetting adjustments may be necessary. We suggest operating your motorcycle or ATV with the settings that work best with your stock valve(s) before making changes.

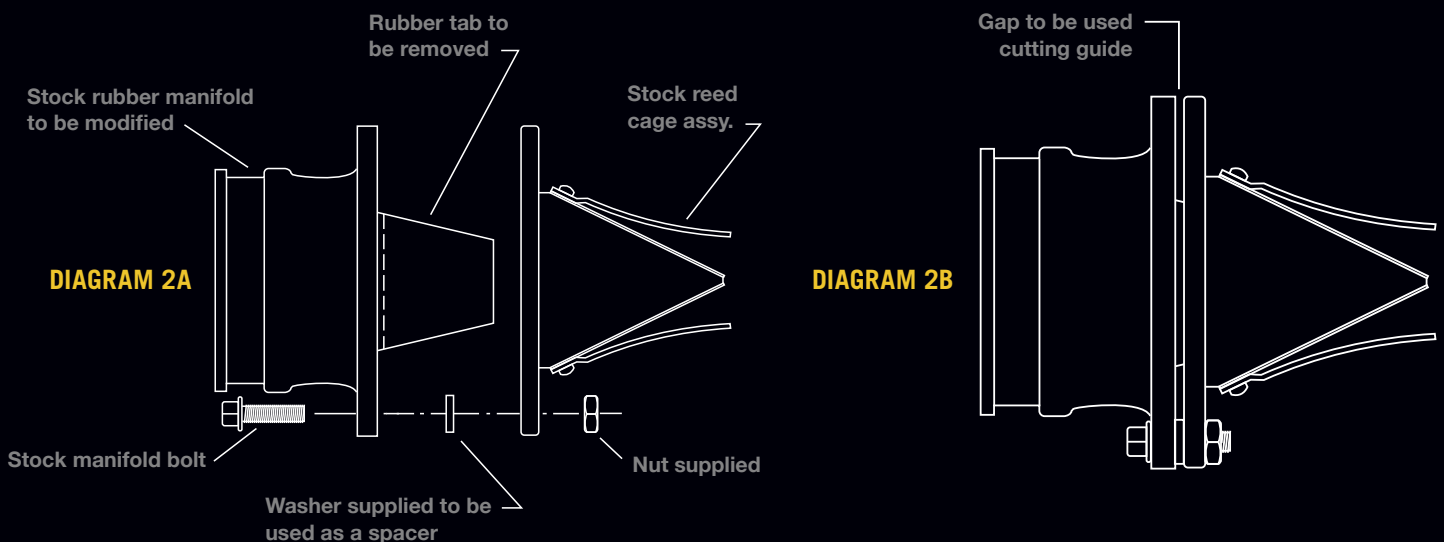

**SUPERIOR TECHNOLOGY. SUPERIOR PERFORMANCE.**